



GDS

German Dredger Services GmbH



Brandstücken 18
22549 Hamburg
Germany



T: +49 40 8708019 10



F: +49 40 8708019 13



info@german-dredger.com



www.german-dredger.com

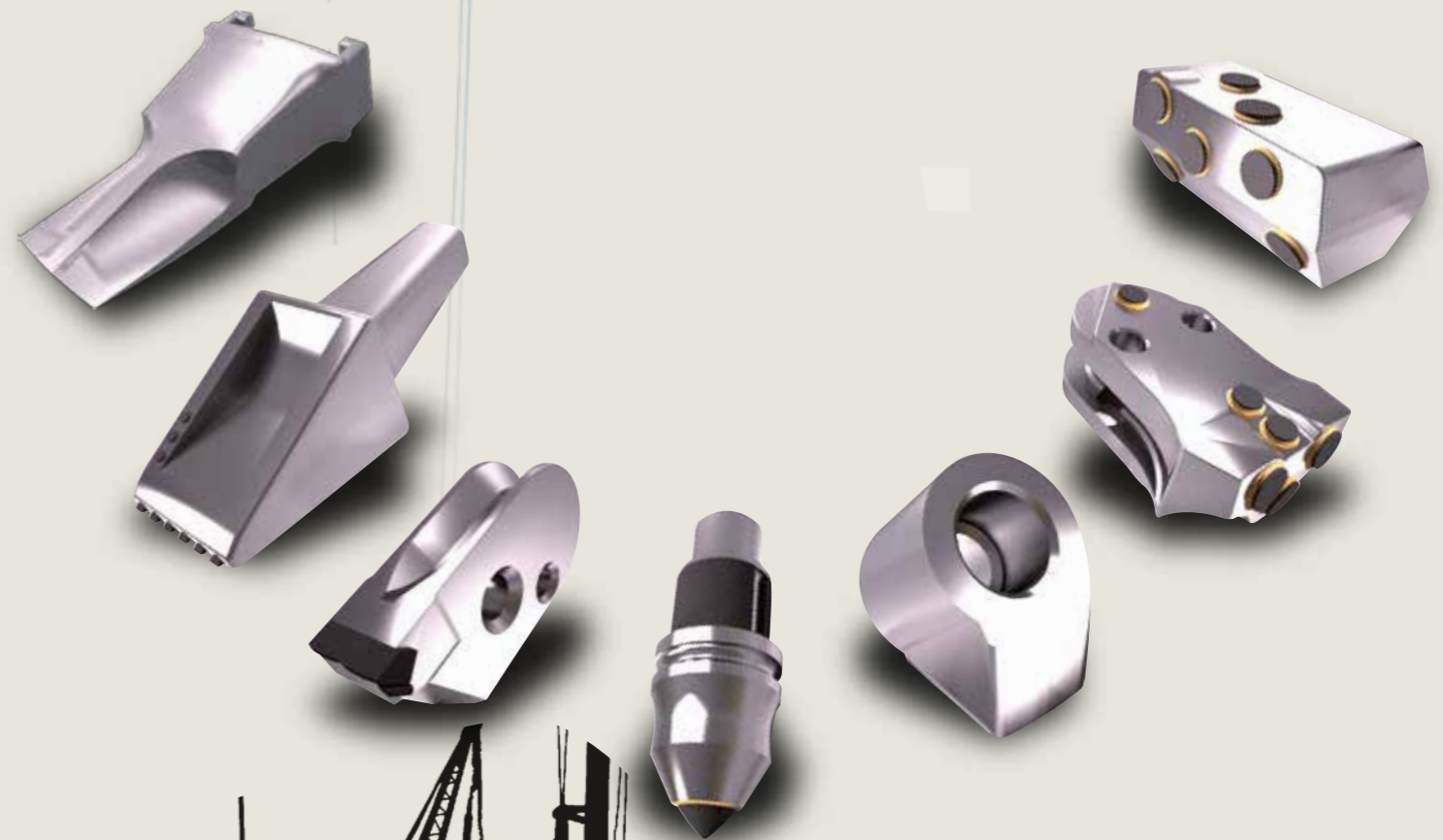

Drilling Equipment Accessories

GDS was established in 2017 to execute geotechnical contract-ing works. In additon GDS has started to give marketing and sales service for piling and anchor products, post tensioning, trench box and renewable energy fields. Therefore GDS has aimed to be solution partner for sector play-ers based on customer satisfaction and continous quaiity principles.



02		Soil Type Cutting Teeth (ETESA)
03		Soil Type Cutting Tools (Esco)
04		Diaphragm Wall Teeth
05		Flat - Brazed Teeth
06		Flat - Brazed Teeth
07		Round Shanks Bits
08		Round Shanks
09		Round Shank Holders
10		Casing Tools
11		Replaceable Block and Holder
12		Carbide Bit For Diaphragm Cutter
13		Pilot Guide and Holder
14		Pilot Guide and Holder For Pilling
15		Pile Spacer and Cating Bits



25/30 Teeth

25 T

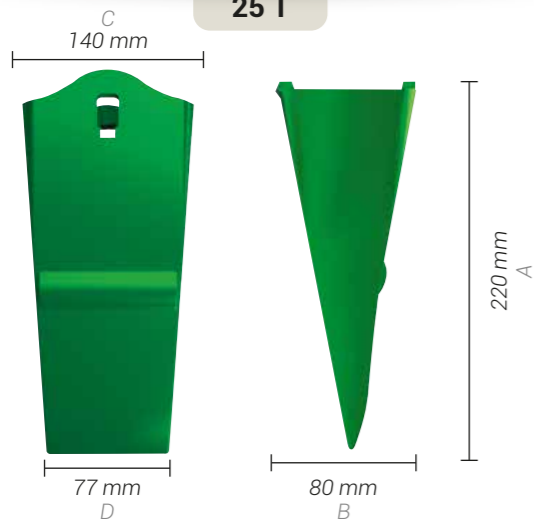

Product	Code	Weight (kg/pcs)
25 Teeth	25 T	2.550
30 Teeth	30 T	3.350

	A	B	C	D
30 T	170 mm	82 mm	78 mm	65 mm

25 Teeth Adaptor |

25 TA

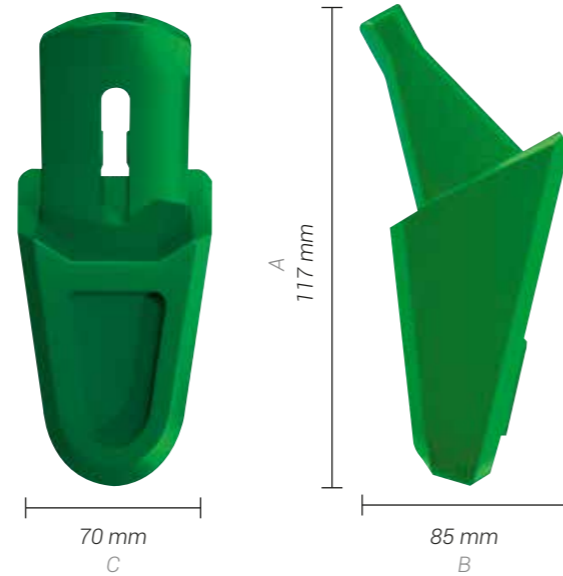

Product	Code	Weight (kg/pcs)
25 Adaptor	25 TA	3.80

25/30 Teeth Adaptor

25 TAC

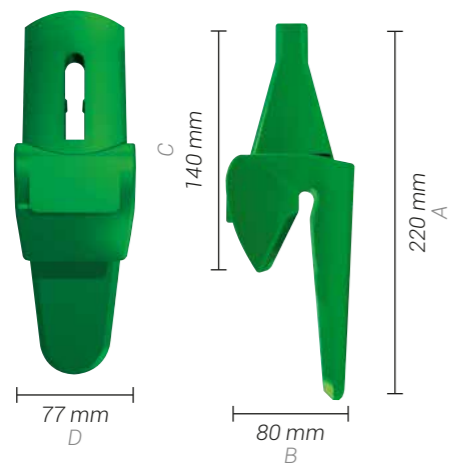

Product	Code	Weight (kg/pcs)
25 Adaptor	25 TAC	3.71
30 Adaptor	30 TAC	3.82

	A	B	C	D
30 TAC	225 mm	80 mm	140 mm	77 mm

25/30 Pin, Lock



Product	Code	Weight (kg/pcs)
25/30 Pin	25/30 PN	0.080
25/30 Lock	25/30 LK	0.015

	A	B
	74 mm	20 mm



18/19/23 Teeth (Threaded Fit)

18 TF

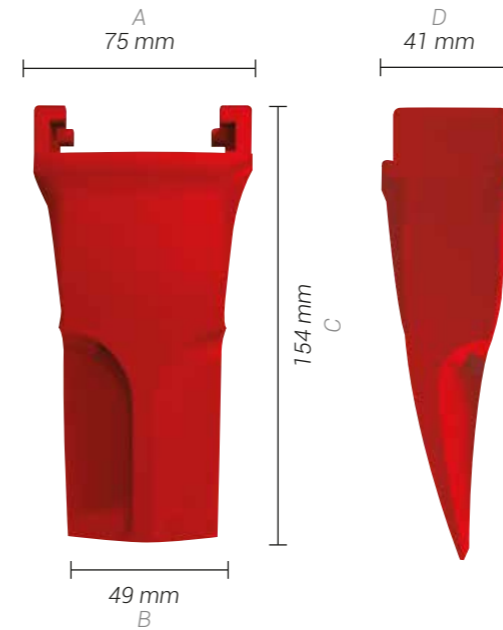

Product	Code	Weight (kg/pcs)
18 Teeth	18 TF	1.44
19 Teeth	19 TF	2.20
23 Teeth	23 TF	3.60

	A	B	C	D
19 TF	78 mm	62 mm	182 mm	46 mm
23 TF	96 mm	74 mm	207 mm	78 mm

18/19/23 Adaptor

18 TFA

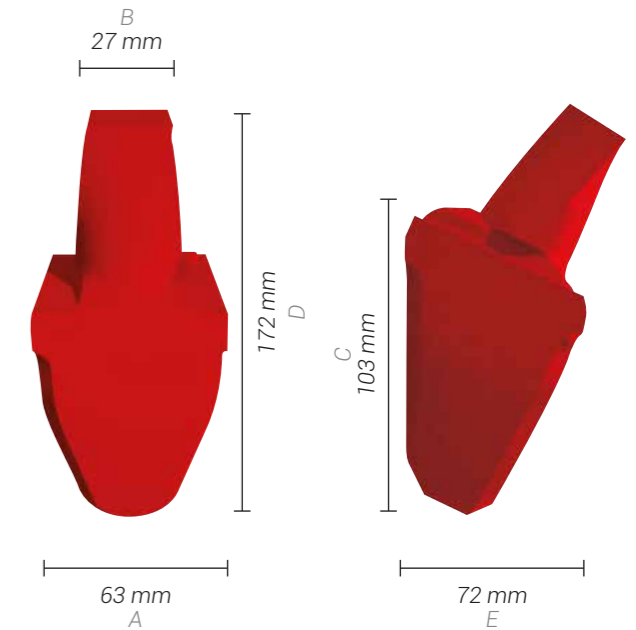

Product	Code	Weight (kg/pcs)
18 Adaptor	18 TFA	2.40
19 Adaptor	19 TFA	3.50
23 Adaptor	23 TFA	6.80

	A	B	C	D	E
19 TFA	73 mm	40 mm	125 mm	180 mm	95 mm
23 TFA	91 mm	61 mm	219 mm	318 mm	110 mm

Main Application: Dense sand, stiff clay, alluvial deposit and weath ered-week rocks
Equipment: Auger and bucket for < 800 mm

18/19/23 Lock

18 LK



Product	Code	Weight (kg/pcs)
18 Lock	18 LK	0.035
19 Lock	19 LK	0.040
23 Lock	23 LK	0.050

	A	B	C
.....	48 mm	16 mm	12 mm



25 TRC Teeth | 25 TRC Tırnak

25 TRC10

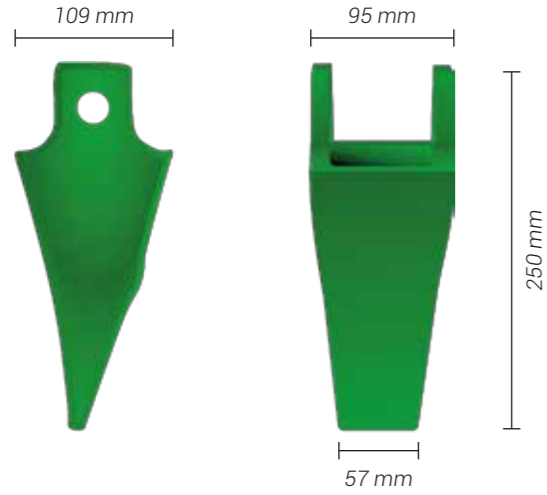

Product / Ürün	Code Kod	Weight (kg/pcs) Ağırlık
25 TRC Teeth	25 TRC10	5.00

25 TRC Teeth | 25 TRC Tırnak

25 TRC12

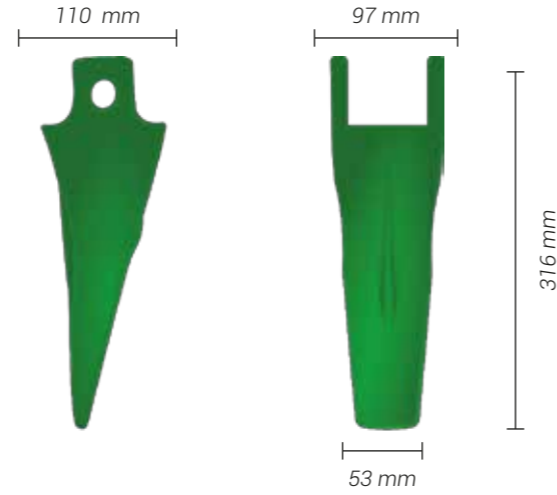

Product / Ürün	Code Kod	Weight (kg/pcs) Ağırlık
25 TRC Teeth	25 TRC12	5.60

25 TRC Adaptor

25 TRCH

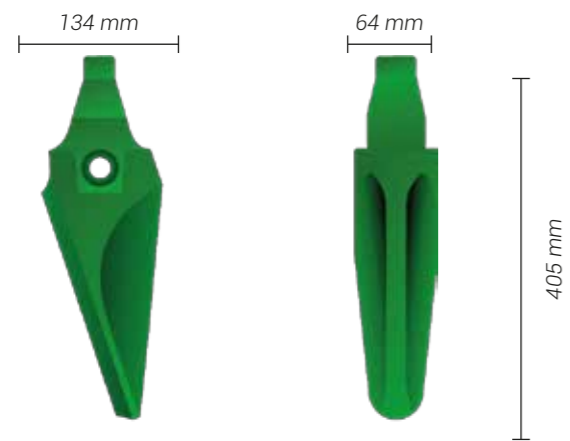

Product	Code	Weight (kg/pcs)
25 TRC Adaptor	25 TRC10	14.00

25 TRC Pin - Retainer

25 TRCPN / TRCLKS

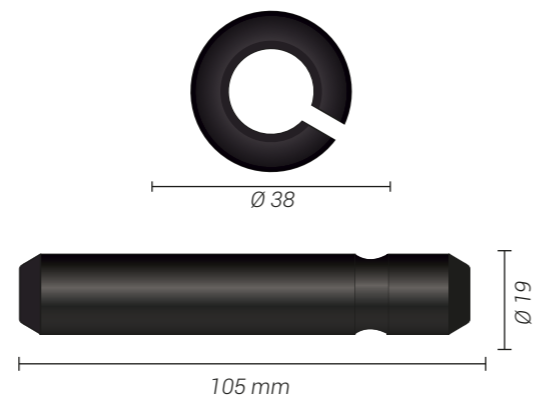

Product	Code	Weight (kg/pcs)
25 - TRC Pin	25 TRCPN	0.045
25 - TRC Retainer	25 TRCLKS	0.225



80 Brazed Teeth

80 TFZC

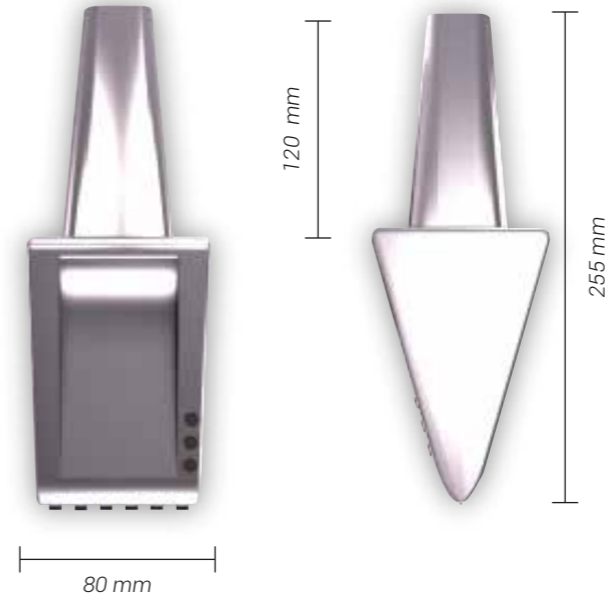

Product	Code	Weight (kg/pcs)
80 Brazed Teeth	80 TFZC	5,35

80 Holder

80 TH

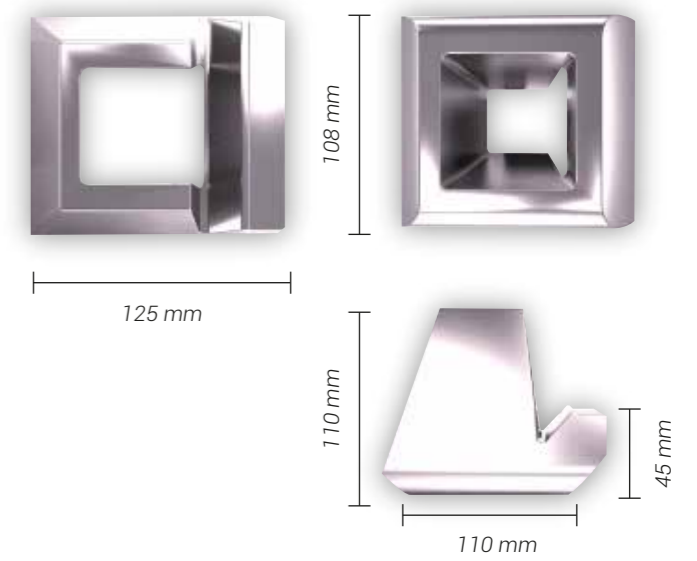

Product	Code	Weight (kg/pcs)
80 Holder	80 TH	4,09

Main Application: Dense sand and moderately strong rock.
Equipment: Auger and bucket for > 1000 mm

80 Bolt and Lock

80 CK / LK

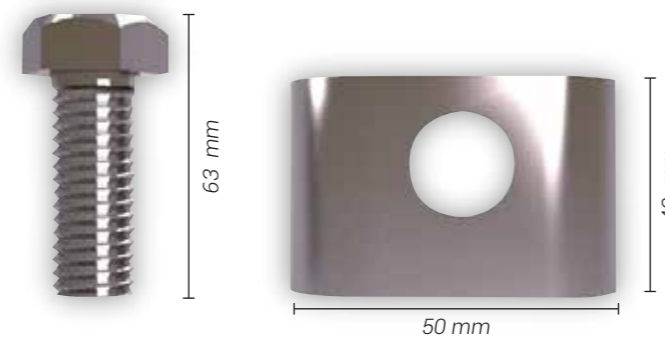

Product	Code	Weight (kg/pcs)
80 Bolt	80 CK	0,080
80 Lock	80 LK	0,015

Flat - Brazed Teeth



55/70 Brazed Teeth

55 TFZC

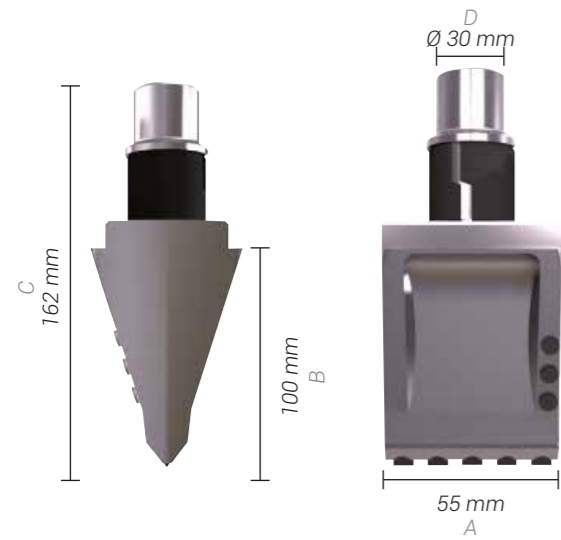

55/70 Round Holder

5570 THR

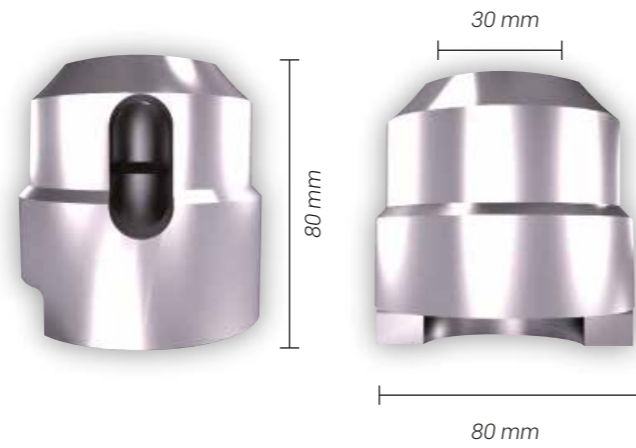

Product	Code	Weight (kg/pcs)
55 Brazed Teeth	55 TFZC	1,85
70 Brazed Teeth	70 TFZC	2,40

	A	B	C	D
70 TFZC	70 mm	102 mm	170 mm	Ø 30 mm

Product	Code	Weight (kg/pcs)
55/70 Holder	5570 THR	1,90

Main Application: Dense sand and moderately strong rock.
 Equipment: 55 TFZC for augers and bucket 600 - 800 mm • 70 TFZC for augers and buckets 800 - 1000 mm

55/70 Inclined Holder

5570 THC

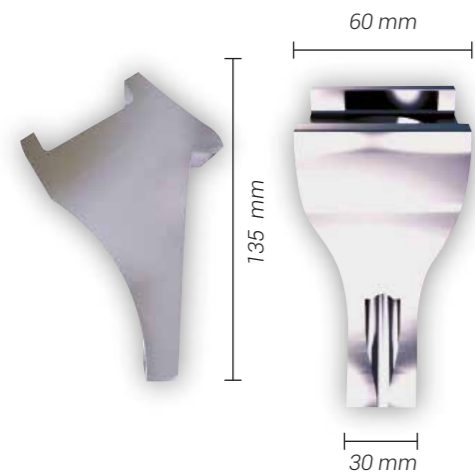

Product	Code	Weight (kg/pcs)
55/70 Holder	5570 THC	1,47

Round Shank Bits



19 mm Bit

19 TB

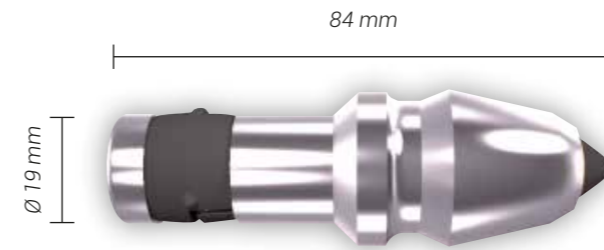

Product	Code	Weight (kg/pcs)
19 Bit / 19 Elmas Uç	19 TB	0,23

Equipment: Augers, bucket and core barrels 100 - 600 mm

25 mm Bit

25 TB

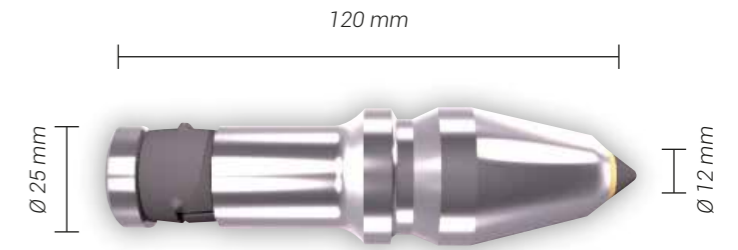

Product	Code	Weight (kg/pcs)
25 Bit / 25 Elmas Uç	25 TB	0,49

Equipment: Augers, bucket and core barrels 100 - 600 mm

25 mm Heavy Duty Bit

25 TBHD

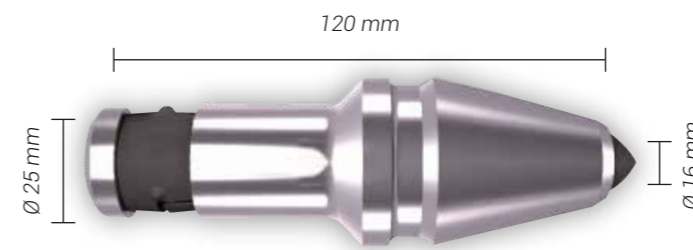

Product	Code	Weight (kg/pcs)
25 HD Bit (Heavy Duty) 25 mm Ağır İş Elmas Uç	58 TBHD	0,55

Equipment: Heavy duty augers, bucket and core barrels 600 - 1000 mm

Round Shank Bits



38 mm Bit

38 TB



Product	Code	Weight (kg/pcs)
38 Bit	38 TB	1,16

Equipment: Augers, bucket and core barrels 1000 - 3000 mm

38 mm Bit (Source Reinforced)

38 TB2



Product	Code	Weight (kg/pcs)
38 Bit /	38 TB2	1,17

Equipment: Augers, bucket and core barrels 1000 - 3000 mm

38 mm Heavy Duty Bit

38 TBHD



Product	Code	Weight (kg/pcs)
38 HD (Heavy Duty) 38 mm	38 TBHD	1,17

Equipment: Augers, bucket and core barrels 1000 - 3000 mm

38 mm Bit (Segmented)

38 TBS



Product	Code	Weight (kg/pcs)
38 Bit	38 TBS	1,17

Equipment: Augers, bucket and core barrels 1000 - 3000 mm

Round Shank Holders



19 mm Holder

19 TBH

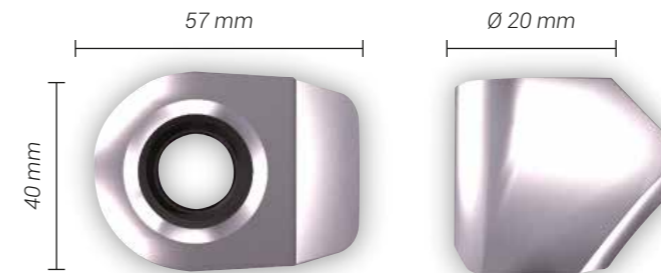

Product	Code	Weight (kg/pcs)
19 Holder	19 TBH	0,45

25 mm Holder

25 TBH

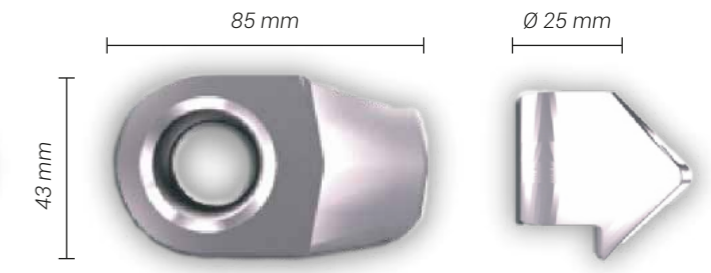

Product	Code	Weight (kg/pcs)
25 Holder /	25 TBH	0,17

38 mm Holder

38 TBH

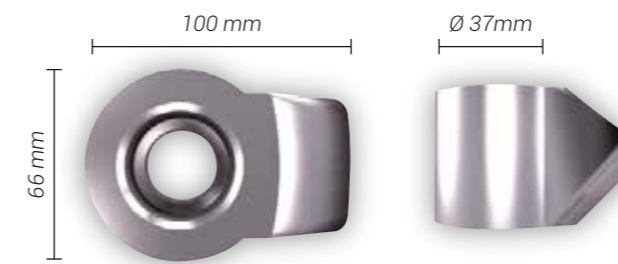

Product	Code	Weight (kg/pcs)
38 Holder	38 TBH	1,77

25-38 mm Brazed and Flat Round Holder

25 TBHR



Product	Code	Weight (kg/pcs)
25 Round Holder	25 TBHR	0,79
38 Round Holder	38 TBHR 2	2,34
38 Round Holder	38 TBHR	1,17

	A	B	C
38 TBHR 2	95 mm	38 mm	Ø 78
38 TBHR	68 mm	38 mm	Ø 65

38 mm Inclined Holder

38 TBHC

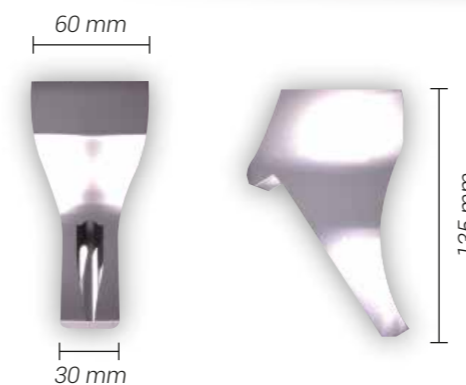

Product	Code	Weight (kg/pcs)
38 Inclined Holder	38 TBHC	1,47

Casing Tools



Conical Ring

60 TC1

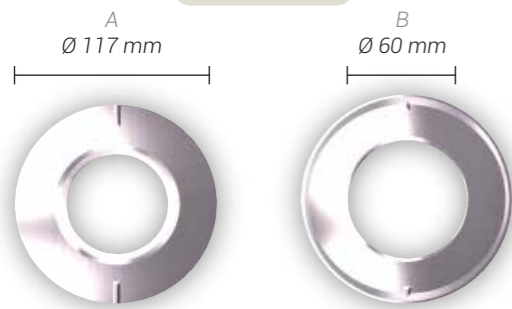

Threaded Ring

60 TT1

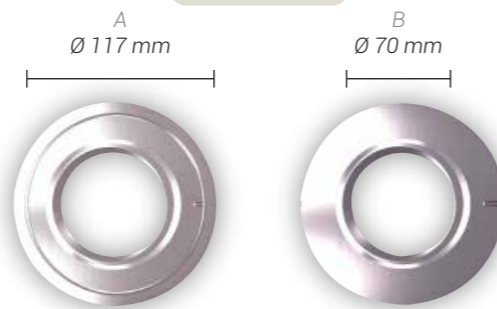

Product	Code	Weight (kg/pcs)
Conical Ring (Tip 1)	60 TC1	0,95
Conical Ring (Tip 2)	66 TC1	1,25

	A	B	C
66 TC1	Ø 117 mm	Ø 60 mm	25 mm

Product	Code	Weight (kg/pcs)
Threaded Ring (Tip 1)	60 TT1	0,66
Threaded Ring (Tip 2)	66 TT1	0,95

	A	B	C
66 TT1	Ø 117 mm	Ø 70 mm	23 mm

Conical Bolt

70 TB1

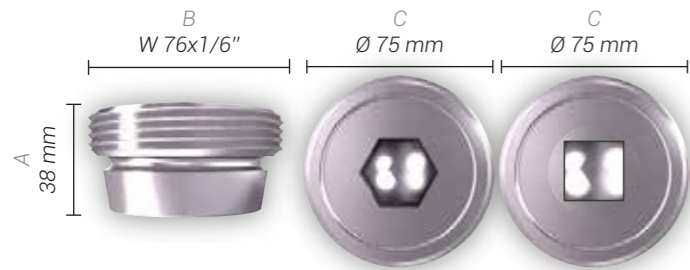

Wedge

40 TW

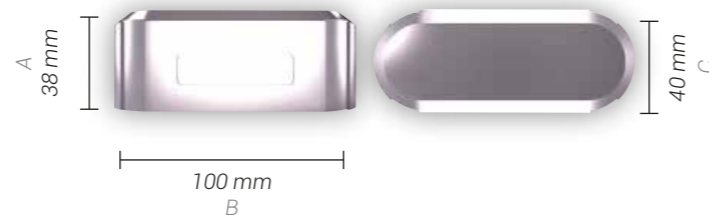

Product	Code	Weight (kg/pcs)
Type 1,6 Corner Conical Bolt	70 TB1	0,91
Type 2,4 Corner Conical Bolt	74 TB2	1,10

	A	B	C
74 TB2	48 mm	W 76x1/6"	Ø 75

Product	Code	Weight (kg/pcs)
Wedge	40 TW	0,96
Wedge	60 TW	0,140

	A	B	C
60 TW	38 mm	100 mm	60

Main Application: 70 TB1 for < 1300/1220 mm / 70 • 74 TB1 for < 1300/1220 mm / 74 TB2 for < 1300/1220 mm

Main Application: 40 TW for < 1300/1220 mm / 60 TW for < 1300/1220 mm

Weld On Block

70 TWC

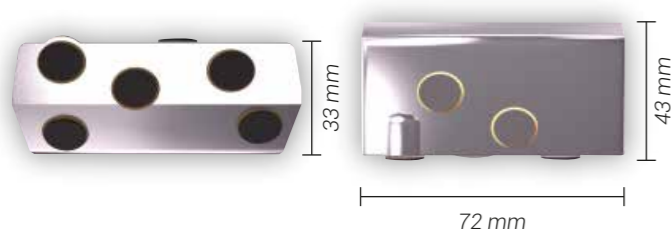

Product	Code	Weight (kg/pcs)
Weld On Block	70 TCW	0,75

Replaceable Block and Holder



Replaceable Block

39 TS

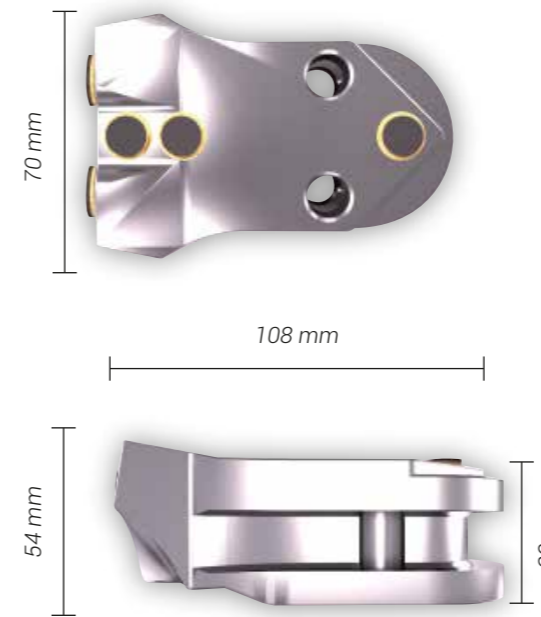

Holder

39 TSH

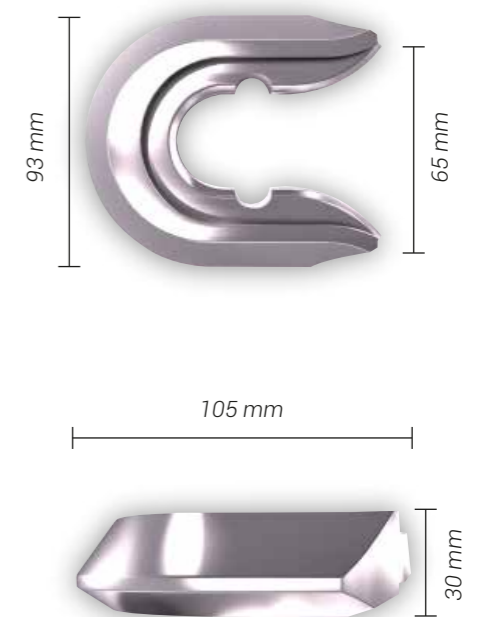

Product	Code	Weight (kg/pcs)
Replaceable Block	39 TS	1,31

Product	Code	Weight (kg/pcs)
Holder	39 TSH	1,00

Main Application: Any type sedimentary formation and weak to strong rock.
Equipment: Core barrels and casing shoes for 600-3000 mm

Pin

3839 PIN

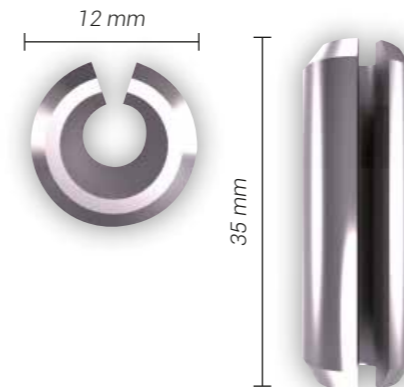

Product	Code	Weight (kg/pcs)
Pin	3839 PIN	0,015

Carbide Bit For Diaphragm Cutter



Cutter Bit-Left (Single Carbide)

36 TFZL

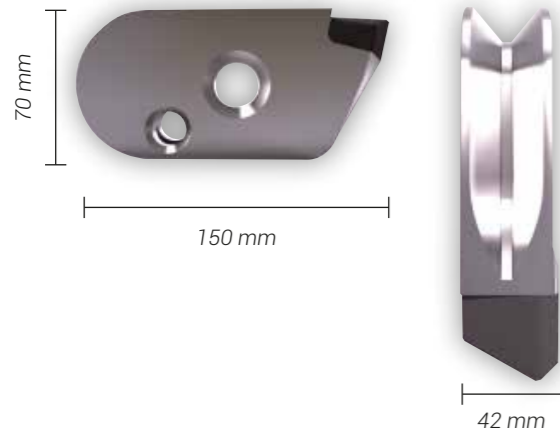

Product	Code	Weight (kg/pcs)
Teeth Left	36 TFZL	2,12

Cutter Bit-Middle (Single Carbide)

36 TFZM



Product	Code	Weight (kg/pcs)
Teeth Middle	36 TFZM	2,15

Cutter Bit-Right (Single Carbide)

36 TFZR

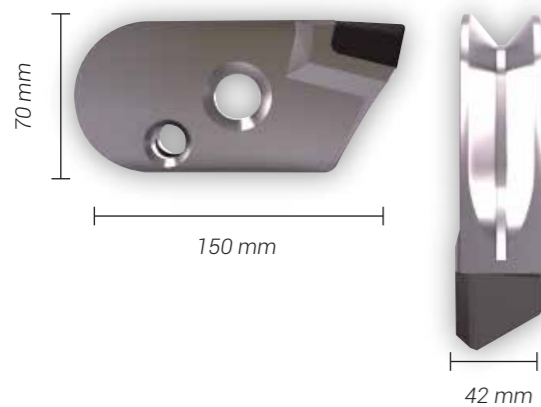

Product	Code	Weight (kg/pcs)
Teeth Middle	36 TFZR	2,12

Main Application: Any type sedimentary formation and weak to strong rock.
Equipment: Core barrels and casing shoes for 600-3000 mm

Pin

36 TFZ PIN

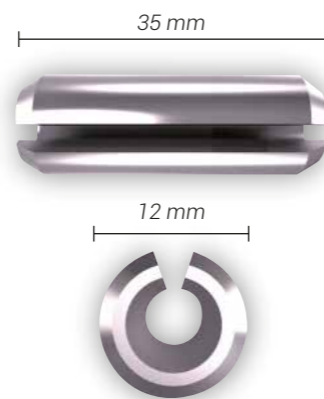

Product	Code	Weight (kg/pcs)
Pin / Pim	36 TFZ PIN	0,015



Pilot Guide and Holder

Pilot Digger Brazed For Anchor

135 TPD 76

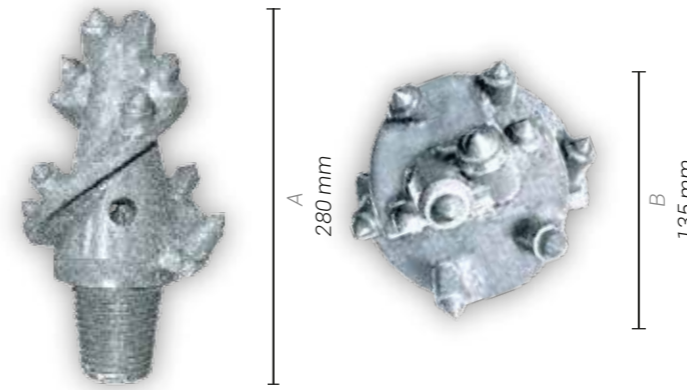

Product	Code	Weight (kg/pcs)
Pilot Guide	135 TPD 76	6,70
Pilot Guide	135 TPD 89	7,30

	A	B
135 TPD 89	280 mm	135 mm

Brazed Pilot Digger For Jet Grouting

115 TPD

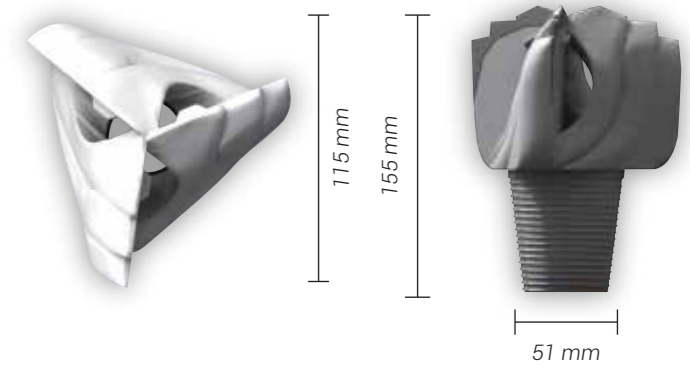

Product	Code	Weight (kg/pcs)
Pilot Guide	115 TPD	3,81

Main Application: Dense sand, stiff clay, alluvial deposit and weathered-week rocks
Equipment: Auger and bucket for < 800 mm

Pilot Guide For Piling

150 TSP

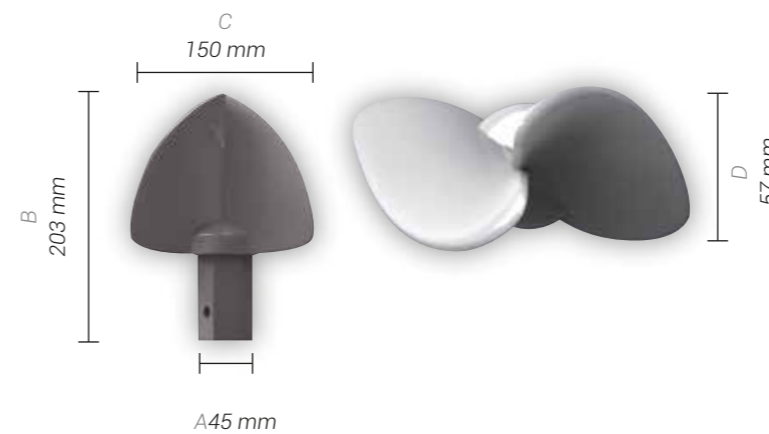

Product	Code	Weight (kg/pcs)
Pilot Guide	150 TSP	2,93
Pilot Guide For Pilling-Clay	300 TSP	8,00

	A	B	C	D
300 TSP	70 mm	414 mm	126 mm	60 mm

Pilot Guide and Holder For Piling



Pilot Guide With 38 mm Bit

240 TRP

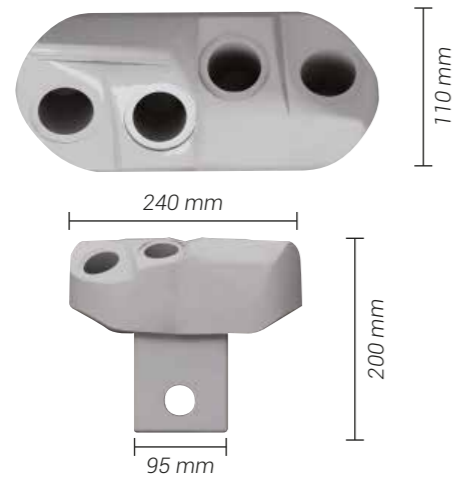

Pilot Guide With 25 mm Bit

180 TRP

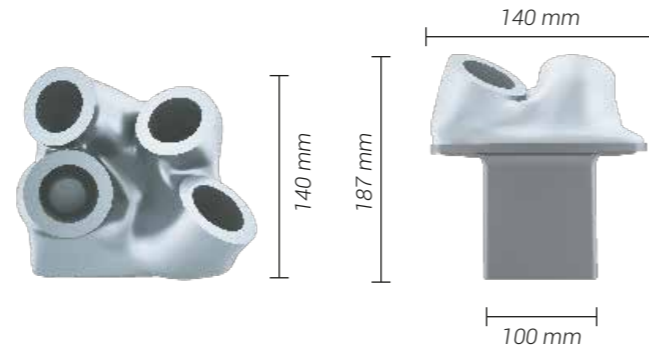

Product	Code	Weight (kg/pcs)
Pilot Guide with 38 mm Bit	240 TRP	19
Main Application: Weak to highly strong rock. Equipment: Augers and buckets for 600 - 3000 mm		

Product	Code	Weight (kg/pcs)
Pilot Guide with 25 mm Bit	180 TRP	19
Main Application: Weak to highly strong rock. Equipment: Augers and buckets for 600 - 3000 mm		

Pilot Guide

220 TSP

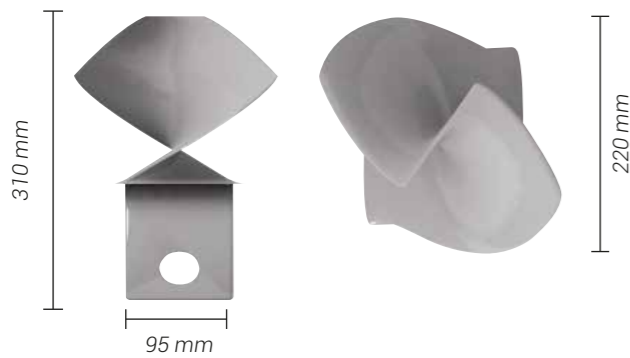

Holder

100 PH

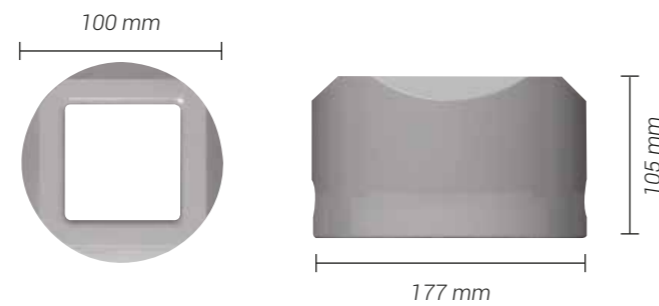

Product	Code	Weight (kg/pcs)
Pilot Guide	220 TSP	18
Main Application: Any type sedimentary formation and weak rock. Equipment: Augers and buckets for 600 - 3000 mm		

Product	Code	Weight (kg/pcs)	
Holder	100 PH	10	
	A	B	C
	102 mm	200 mm	107

Pile Spacer and Cating Bits



19 mm Bits

19 WT

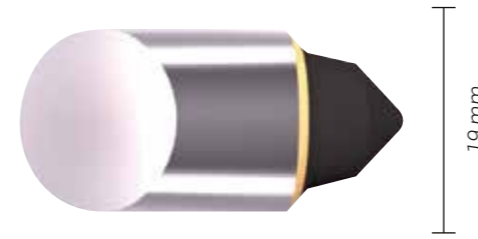

Psc Box	Code	Weight (kg/pcs)
500	19 WT	0,05

25 mm Bits

115 TPD



Psc Box	Code	Weight (kg/pcs)
150	25 WT	0,15

27 mm Bits

27 WT



Psc Box	Code	Weight (kg/pcs)
150	27 WT	0,18

Pile Spacer

FKP 50 / 75



- The advantage of pile spacer:
- Keeping the central position of reinforcement in the pile
- Easy to fix during reinforcement installation
- Provide the corrosion protection due to well concrete cover

Product	Code	Weight (kg/pcs)
Piling Spacer (50 mm)	FKP 50	50,0
Piling Spacer (75 mm)	FKP 75	65,0

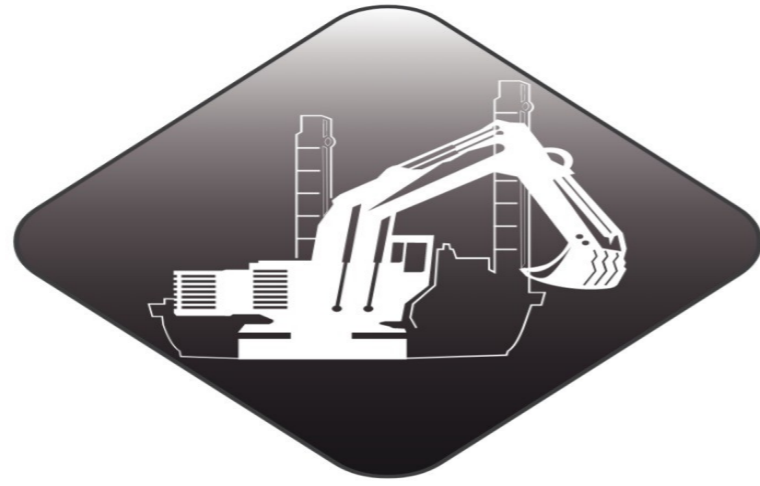

GDS

German Dredger Services GmbH

